

ART IN PUBLIC PLACES PUBLIC ART OPPORTUNITY



SURREATTS-CLINTON BRANCH LIBRARY • INTERIOR INSTALLATION 9400 PISCATAWAY RD. CLINTON, MD 20735

Request for Qualifications

Prince George's County, MD

PROJECT GENERAL INFORMATION

The Surratts-Clinton Branch Library was originally built during the energy crunch in the 1970's which led to the construction of the building being a model for energy efficiency.

Designed by AS Architects and MSR Joint Venture, the interior/ exterior major renovation plans include a complete gutting of the building, an installation of lighted panels, a new canopy addition, and an interior redesign.

SUBMISSION DEADLINE

DECEMBER 4, 2020

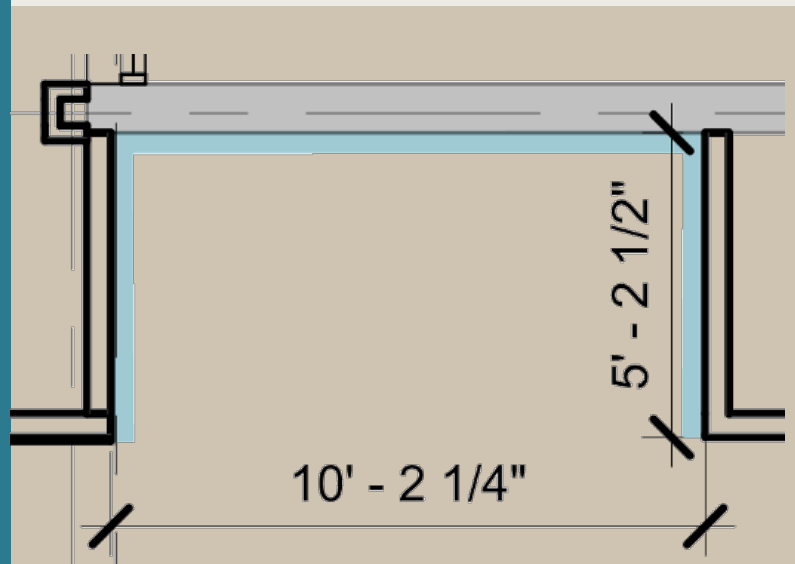
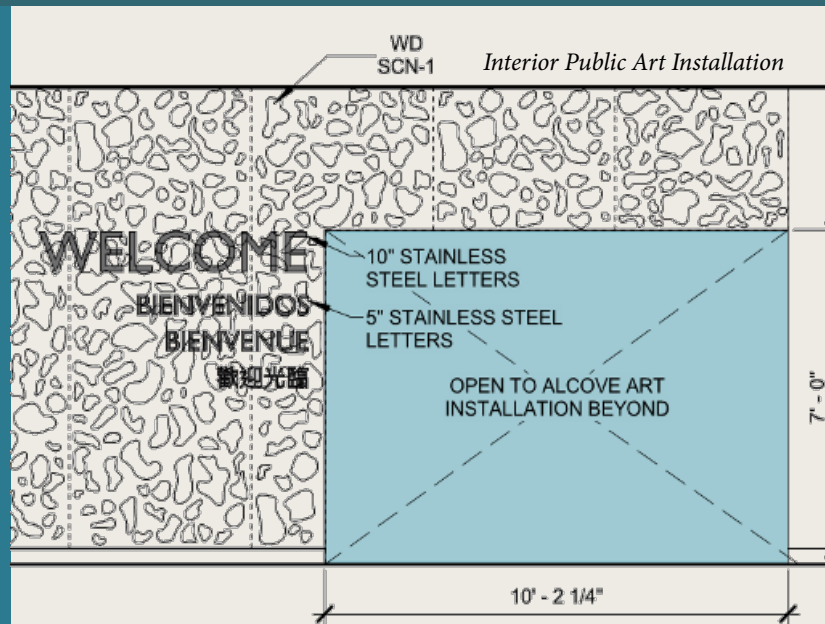

The Surratts-Clinton Branch Library will also be incorporating a public art piece that will be placed in their welcome area.



DESIGN VALUES

- Create a mural along welcome area alcove.
 - Preferred materials are glass, mosaics, ceramics. Durable, non-hazardous, and easily cleanable.
 - The art must take inspiration from the Chesapeake Bay and local natural environment.
 - Artwork shall complement the color scheme of the interiors below.
- 
- Be able to install the mural on an interior brick wall and metal stud walls with gypsum board

ROLE OF ARTIST(S)

- Provide concept design ideas through renderings or other media.
- Coordinate design ideas with building/landscape infrastructure.
- Collaborate with community/project stakeholders.
- Generate final rendering presentation materials, drawings, a model, and related specifications in sufficient detail and in the format required to convey the design intent for the place indicated on the site.
- Fully execute interior installation as detailed.

ELIGIBILITY REQUIREMENTS

- Professional artist(s) and design professionals are invited to apply as individuals or teams.
- Candidates must demonstrate collaborative, project team experience working with other artist and design professionals (engineers, architects, environmental and urban planners, or landscape architects) and direct experience with exterior sculpture design and installation.
- Local artists are encouraged to apply. Artists and design professionals that are residents/have studios in Prince George's County are encouraged to apply.

PROJECT BUDGET

\$76,000

- Project budget, including artist design fee, materials, fabrication, installation, travel and any other project expenses.

SELECTION PROCESS & CRITERIA

After the submission deadline, the Prince George's County Arts and Humanities Council public art staff will convene an Art Advisory Committee composed of representatives of the community, artist/design professionals, and project team members including Prince George's County Memorial Library System (PGCMLS) representative, AS Architects and MSR Joint Venture representative and Council District 2 representative.

The Art Advisory Committee will screen submissions to establish a qualified candidate pool to be considered for this commission. Pre-qualified artists and/or artist teams will be presented to the County appointed Arts in Public Places (AIPP) Panel which will decide who will be awarded the contract.

The Art Advisory Committee will use the following criteria to make their selection:

- Artistic merit as evidenced by submitted digital representation of past work samples
- Appropriateness of the artist's medium, style, and previous professional experience as they relate to the public goals and design values of this project
- Experience with projects of similar scale and scope, including a demonstrated ability to successfully collaborate with public agencies, engage in a successful public review process, work well with diverse community groups, and plan and carry out successful community engagement activities,
- Artist's ability to successfully work within the project timeline and budget.

The Art Advisory Committee will review applicants' submitted materials, have an opportunity to ask clarifying questions of applicants initial ideas and approaches to the project in broad conceptual terms and develop a ranked list of two to three qualified candidates who will be invited for interviews. Finalists will be paid an honorarium to produce a more detailed concept proposal. Following the interview/proposal stage and reference checks, the Prince George's County Art in Public Places Panel will vote to approve the final artist recommendation.

Upon approval, the selected artist or artist team will be issued a design contract. Prince George's Arts and Humanities Council serves as the County's AIPP program coordinator overseeing contract issuance and deliverables and overall project management.

SUBMISSION DEADLINE DECEMBER 4, 2020

Please submit the following to publicart@pgahc.org

- Name and contact information including resident/primary studio address.
- Statement of interest which describes how you will address the project design values.
- Preliminary ideas for how you would approach the project and what uniquely bring to enhance overall vision.
- Resume/Artist Vitae outlining your professional accomplishments. (If submitting as a team, please identify team leader and include resumes for each team member.)
- Images of most recent work that represents your artistic process. (Please limit to 10 images per artist or team member)
- Three professional references that include name, affiliated organization (if appropriate), email address, and phone number.

RFQ may also be posted on a national platform.

ANTICIPATED SCHEDULE

Submission of Qualifications
DECEMBER 4, 2020

Interviews with Selected Finalists:
DECEMBER 21, 2020

Award of Contract:
JANUARY 4, 2021

Installation:
JUNE 2021

Due to construction schedules these dates are subjected to change

For questions and all inquires contact:
Rhonda Dallas: rdallas@pgahc.org